

UM6HE1TCX

ISUZU

ISUZU MOTORS ENGINE SALES INC.

UM6HE1TCX

DIMENSIONS (mm)

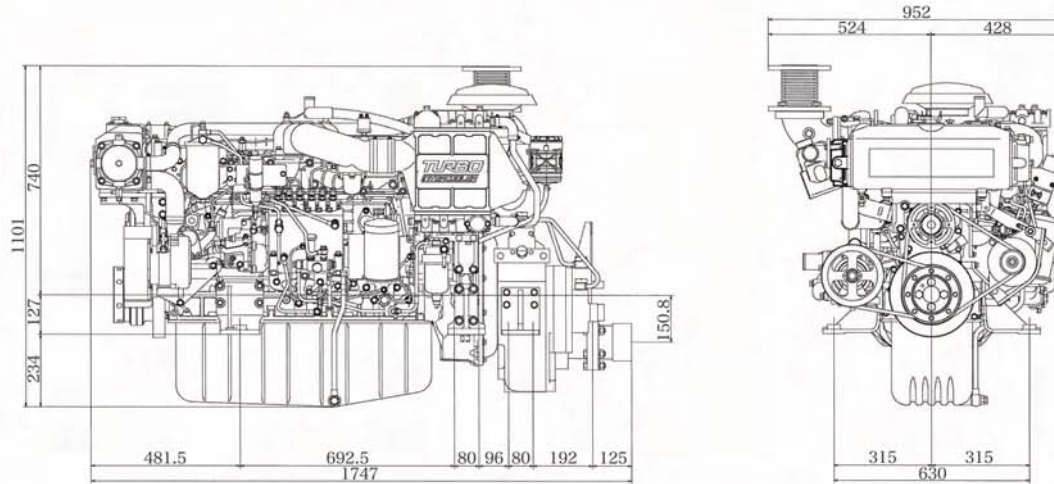

PERFORMANCE CURVES

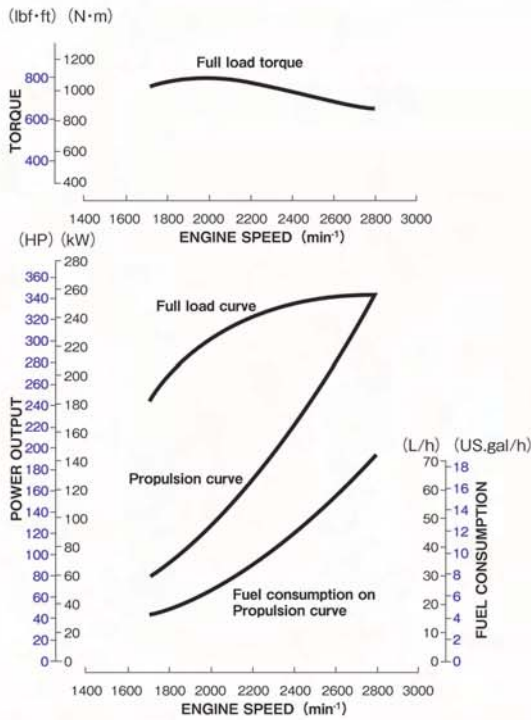

ENGINE SPECIFICATIONS

Configuration		6-cylinder, vertical in-line, 4-cycle diesel engine	
Bore x Stroke		mm (in) 110 x 125 (4.33 x 4.92)	
Displacement		Lit. (cid) 7.127 (434)	
Rated output	kW(PS)/min ⁻¹	Medium duty	235 (320) / 2700
		Light duty	257 (350) / 2800
Application		Commercial use	
Governor type		Mechanical	
Combustion type		Direct injection	
Aspiration		Turbo charged / Intercooler	
Exhaust gas status		IMO Tier II	
Engine weight	kg (lb)	Engine	720 (1,587)
		with MGN40G	898 (1,980)
Fuel used		Diesel fuel	
Starter		V-kW	24 - 4.5
Alternator		V A	24 50
Lubrication method		Full flow pressure circulation	
Cooling method		Freshwater, full flow pressure circulation (Seawater, indirect)	
Heat exchanger (seawater circulation)		Multi-tube type (freshwater→seawater)	
Intercooler		Multi-tube type (seawater circulation)	
Rotation direction	Crankshaft	Right (clockwise) viewed from front of engine	
	Propeller shaft	Right (clockwise) viewed from stern	
Idling speed		min ⁻¹	550
Marine gear	Marine Gear Model	MGN40G	
	Clutch type	Wet, Multi-plate hydraulic type	
	Reverse type	Constant-mesh type gear	
	Reduction ratio	2.33, 2.91, 3.45	

Specifications subject to change without notice

ACCESSORIES

Standard

- Installation kit
- Kingston valve
- Battery relay
- Extension harness (5m)
- Seawater pump impeller *
- Bilge pump
- Control head
- Instrument panel
- Oil drain pump
- Blow-by pipe
- V-belt *
- Tool kit
- Owner's manual

* spare parts

Option

- Extension harness (5m)
- Control cable (4m,6m,10m,12m)
- Stop cable (4m,6m,8m)

ISUZU MOTORS ENGINE SALES INC.

<http://www.isuzumarine.co.jp>



ISUZU UM6HE1TCX DIESEL ENGINE GEAR LESS

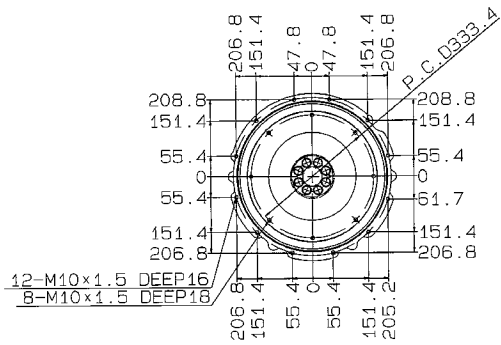

HOUSING, FLYWHEEL DETAIL

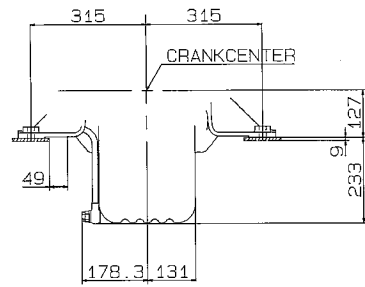

VIEW A

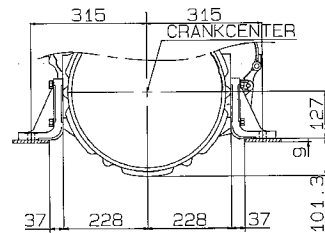

VIEW B

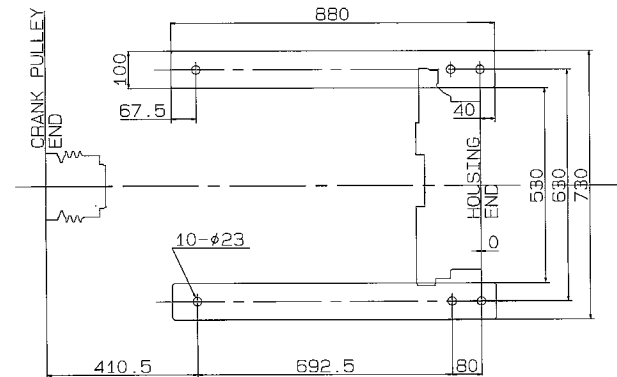

ENGINE MOUNTING

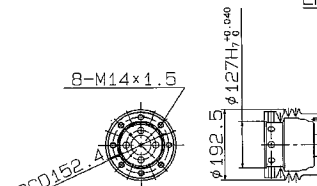
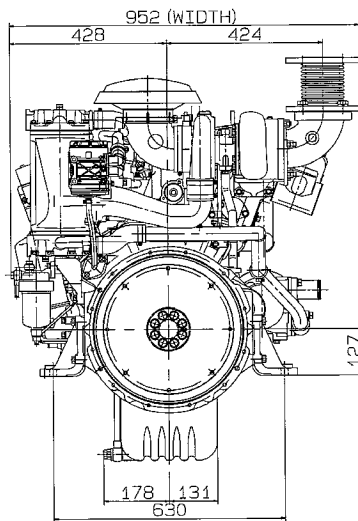
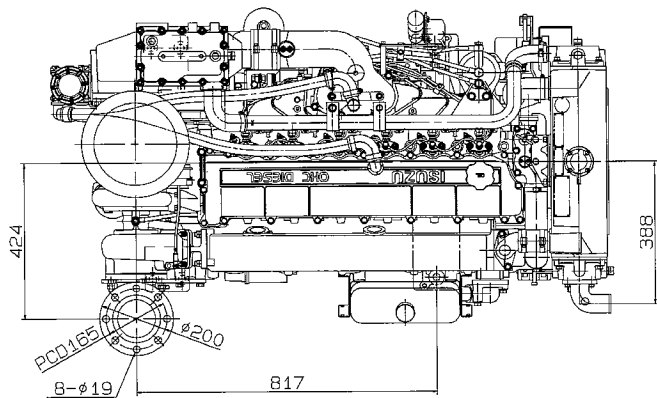

CRANK PULLEY DETAIL

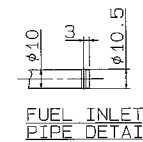

FUEL INLET PIPE DETAIL

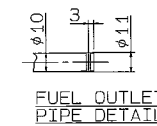

FUEL OUTLET PIPE DETAIL

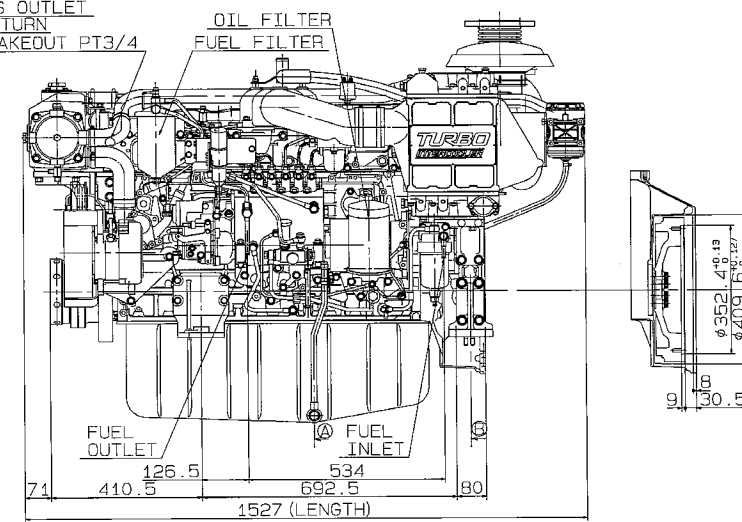
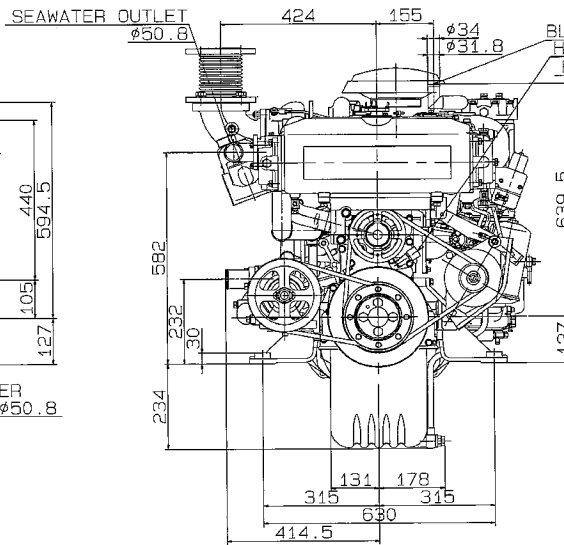
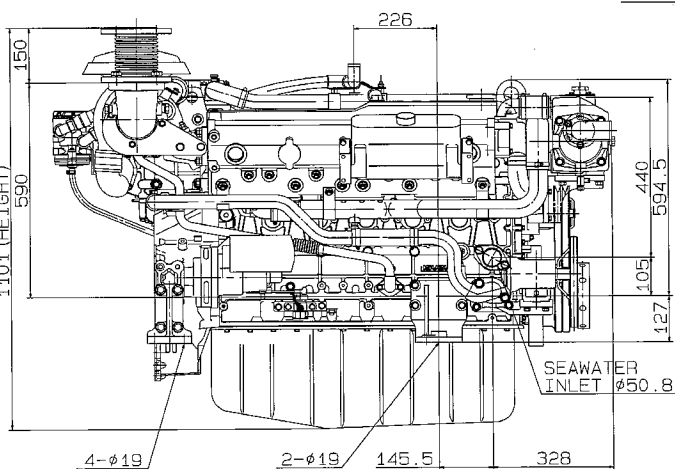

ISUZU UM6HE1TCX DIESEL ENGINE MGN40G-2

