

Tier 2

**A 132.3 kW turbo-charged
6-cylinder engine**

6BG1TC

- Environmental performance that meets Tier 2 regulations
- Powerful 132.3 kW output
- Environmentally friendly and economical with low fuel consumption
- Lightweight and compact, with outstanding quiet performance
- Highly rated around the world for reliability and durability

► Suitable for a wide range of applications



Excavator

General Power



* Image shown may not reflect actual engine configuration.

Engine data for general power specifications

Specifications			
Engine Model	6BG1TC		
Engine Characteristics	4-Cycle, Water-Cooled, Vertical In-Line		
Valvetrain Configuration	Over Head Valve		
Type of Aspiration	Turbocharged and Charge Air Cooled		
Type of Injection	Direct		
No. of Cylinders	6		
Bore x Stroke	105 x 125 mm	4.13 x 4.92 in	
Displacement	6.494 liters	396 cu.in	
Overall Dimensions	Length	1201 mm	47.28 in
	Width	722 mm	28.42 in
	Height	971 mm	38.22 in
Dry Weight	463 kg	1021 lb	
Rated Output	132.3 / 2200 kW/min ⁻¹	177 / 2200 HP/rpm	
Max. Torque	637 / 1800 N·m/min ⁻¹	469 / 1800 lb·ft/rpm	

* The data on this data sheet are for information purposes only and are not binding values.

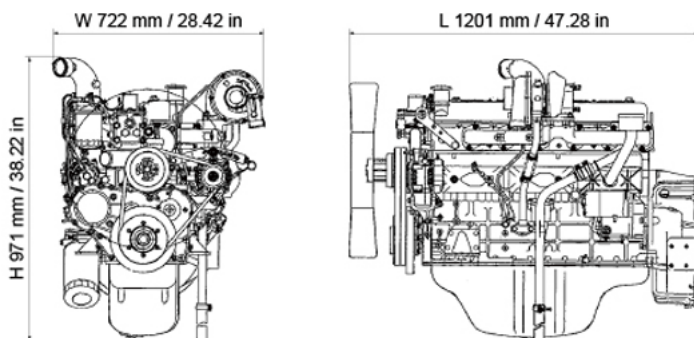

* Appearance diagrams shown may not reflect actual engine configuration.
* Final dimensions are dependent on selected options.

Performance Curve

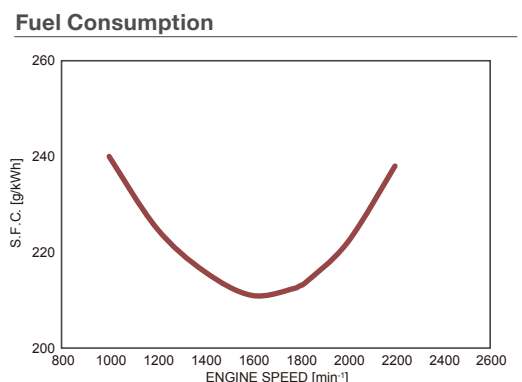
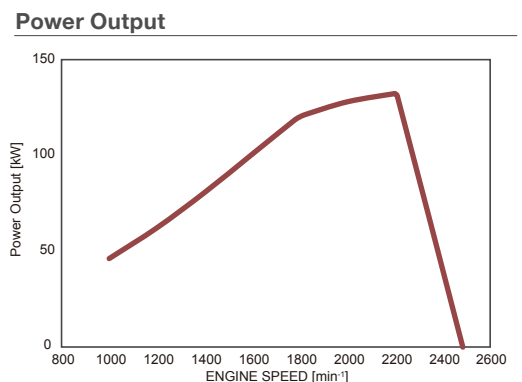
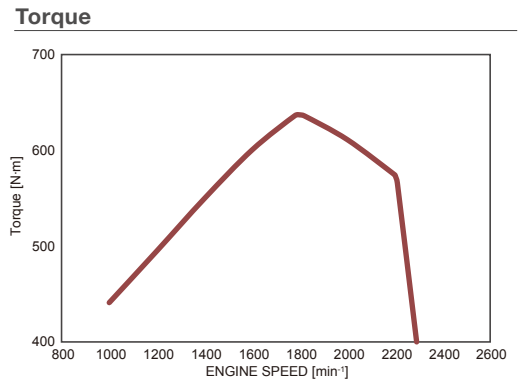

* Performance curves shown are representative.